



*Beautiful* **LIVING**  
Transforming **conservatories** into  
an all year round living space

The image shows a bright, airy interior space, likely a living area, with a high ceiling. A prominent feature is a large, multi-paned window or skylight structure that allows ample natural light. The ceiling is white, and the walls are also white, contributing to the bright atmosphere. The text 'Transforming LIVING SPACES' is overlaid on the upper part of the image in a white, elegant font. The word 'Transforming' is in a large, flowing script, while 'LIVING SPACES' is in a smaller, clean, sans-serif font. The overall aesthetic is modern and minimalist.

*Transforming*  
LIVING SPACES

# contents

PAGE 04	WELCOME
PAGE 06	LIGHTWEIGHT TILED ROOF
PAGE 08	LIGHTWEIGHT TILED ROOF
PAGE 10	LIGHTWEIGHT SLATE ROOF
PAGE 12	SKYVISTA GLASS PANEL FEATURE
PAGE 16	SupaLite PLUS+
PAGE 17	SupaLite ECO ROOF
PAGE 18	ROOF COVERINGS
PAGE 20	ACCESSORIES
PAGE 22	SupaLite ORANGERIES
PAGE 26	SUPERIOR GLAZED ALUMINUM VERANDAS
PAGE 28	BUILDING REGULATIONS
PAGE 30	FAQ'S

# Welcome

Whether you are considering a conservatory roof replacement, new build conservatory or an extension, we have the solution for you.

The SupaLite roof systems have all undergone exhaustive testing following years of research and design. It's imperative that homeowners make the right decision when investing in a solid roof to ensure the building is a safe and habitable place that also adds value to the property.

Specifying the SupaLite Roof will ensure the correct configuration and overall solution for your all year round living space.

*Quality living.*  
IT STARTS HERE

Transforming conservatories into  
all year round living spaces



## 5 Reasons

to choose a **SupaLite Roof**

- ✓ Save money on heating costs
- ✓ Roof system engineered and tested to meet all Building Regulations requirements
- ✓ Transforms a conservatory into an extension
- ✓ Add significant value to your home
- ✓ Increase your living & entertaining space

# Lightweight **TILED ROOF**

*Controlled temperature,*  
WHATEVER THE WEATHER

**STRUCTURAL** lightweight aluminium roof, engineered and designed to last a lifetime

**INCREDIBLE** U-Value with increased thermal performance which saves money on your energy bills

**WIDE CHOICE** of tile and slate colours to either match or contrast your existing property

**ADD VALUE** to your home with the feel of an extension for all year round living space

# Fall in love with your conservatory again

The transformation you will benefit from is incredible. Not only will you greatly reduce the energy costs by retaining a moderated living temperature in your conservatory, but you will also have more occasions for spending time in your conservatory.

Before



After



*We only used our old conservatory for half of the year as it was either too hot in summer or too cold in Winter. By having the roof replaced with a SupaLite Roof, we now use this fabulous room all year round, morning till late at night. What a transformation!*

Mr & Mrs Bramhall

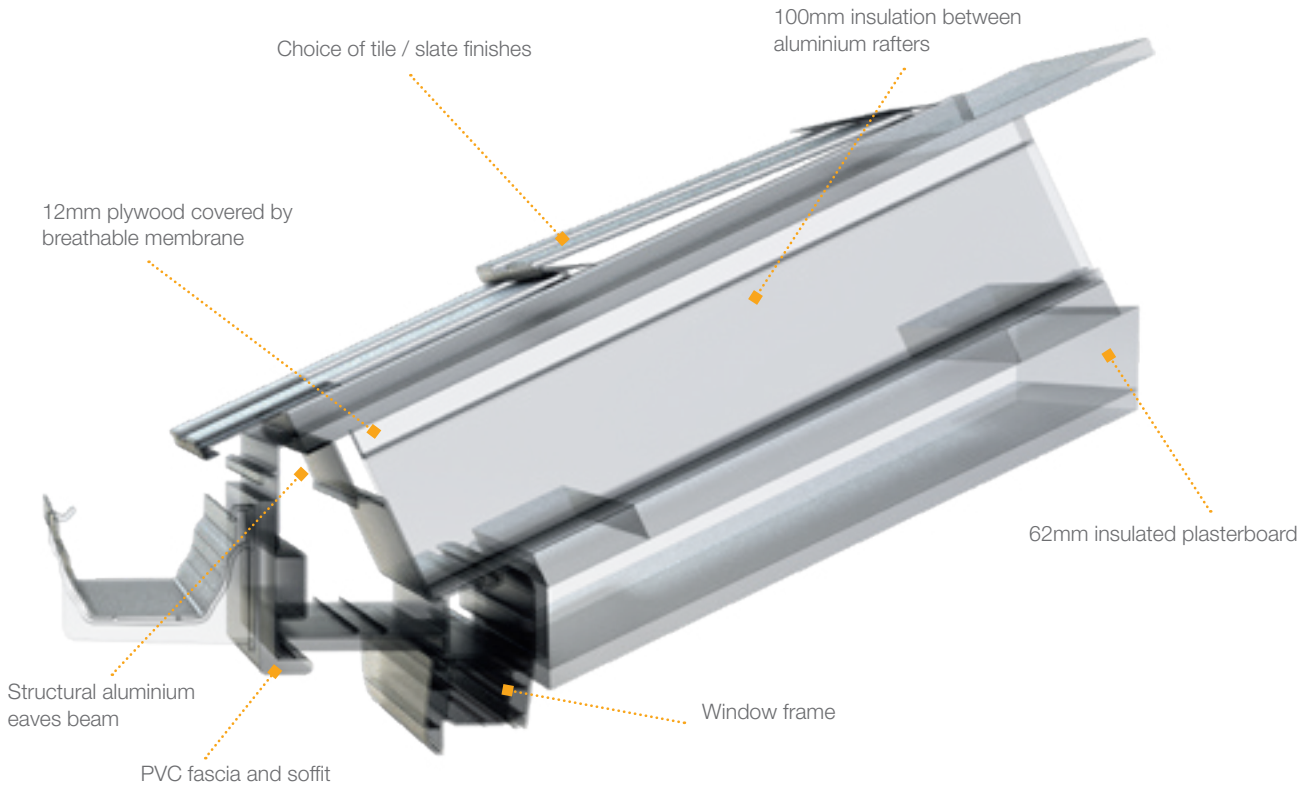

Transforming conservatories into year round living spaces



# Lightweight **TILED ROOF**

*Building your vision.*  
CREATING REALITY

**UNIQUE** fascia and soffit detail with options for external lighting to give the wow factor in the evenings

**COLOUR** choice of fascias, soffits and guttering to either match or contrast your existing property

**10 YEAR GUARANTEE** The SupaLite Roof is a tried and tested product, with the system and some of its products holding accreditations such as BBA, BRE and CORGI

**APPROVED** with Building Regulations



## New Build, Replacement Roof or Commercial Building

The SupaLite Roof can be installed on new build conservatories or on new extensions.

Many commercial properties are now fitting SupaLite Roofs on restaurants, nursing homes, educational buildings and extensions.

These buildings will also benefit from the added property values gained by installing a SupaLite Roof.



### *Dream* Living Space

When SupaLite roofs are installed, many customers remodel their conservatories internally to give the feel of a true lounge or dining room. With plastered ceilings and our optional internal downlighting, it gives you a dream living space.

## Lightweight **SLATE ROOF**

*A complete investment,*  
ADDING VALUE TO YOUR PROPERTY

### **LIGHTWEIGHT**

Even with SupaLite's 150mm of insulation, plasterboard, tiles, plywood, structural aluminium ridge, rafters and eaves beam – it will not be much heavier than a typical glass roof.

## Ultra-modern with a Traditional Look

The SupaLite Slate roof comes with several colour options. The SupaLite Slate option can add splendour, elegance and tradition to your home. It is authentically shaped with textured surfaces and edges moulded from traditional slates, that make it almost indistinguishable from natural slate – yet it has an even more refined appearance. This lightweight slate will not crack, break or delaminate, and its product formulation and manufacturing processes provide durability, performance, and longevity for many years to come.



Aluminium rafter section

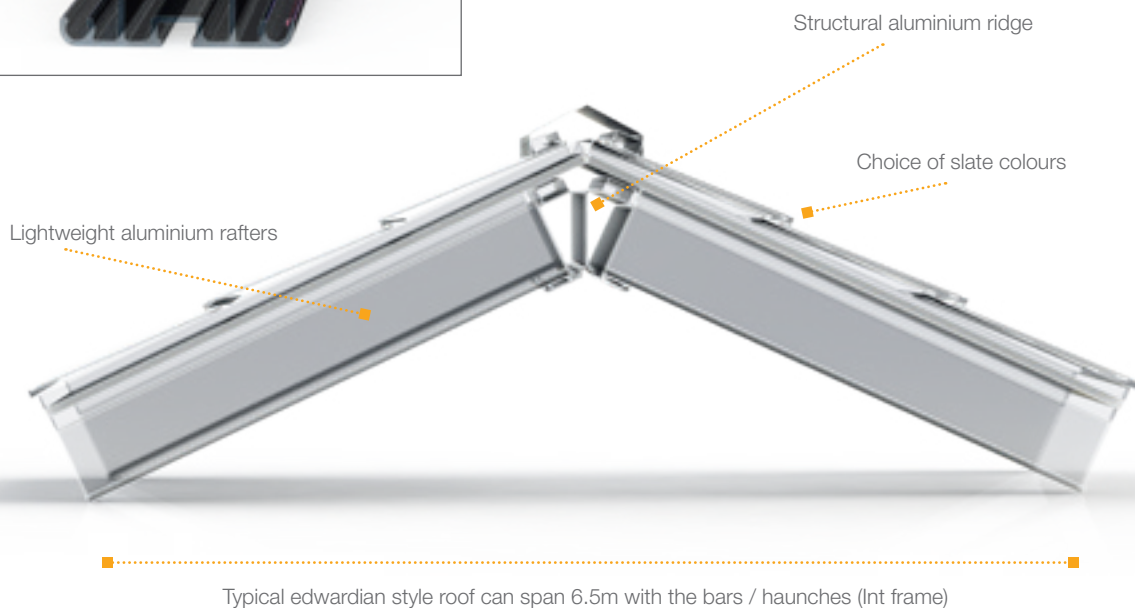
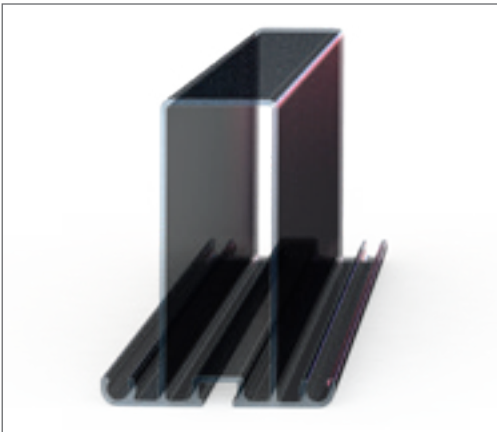

# SKYVISTA

## Glass Panel Feature

*The place for you*  
TO RELAX AND ENJOY

The ultra-chic SkyVista panel has excellent aesthetic and great solar control, meaning you can regulate the temperature of your conservatory whilst allowing plenty of natural light to flow through.

## A Beautiful and Practical Blend of Lightweight Tiles and Glass Panels

Control the temperature of your conservatory whilst making the most of natural light with our new product, the SupaLite SkyVista – a combination of our roof and glass panels.

Unlike traditional conservatory roofs, the technology behind the SkyVista means your conservatory will be cool and comfortable on hot sunny days and warm and cosy on cold winter days. Plus, you won't have to climb up ladders to clean your roof, as the SkyVista glass is self-cleaning!

The SkyVista can be configured to numerous conservatory styles, including Edwardian, Victorian and Lean-to, and it comes in two colour options, blue and neutral.

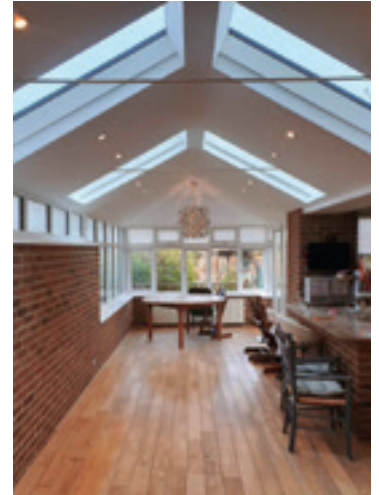

**5 Reasons** to choose a **SkyVista**

- ✓ Transforms your conservatory into a solid roof system, without losing overhead natural light.
- ✓ The panels are available to be installed with both, tile and slate finishing options.
- ✓ Awarding you with the best of both – part glass alongside our aluminium solid roof system.
- ✓ Stable thermal control within your newly transformed living space.
- ✓ Give your home a makeover with our stylish glass panel feature.

# SKYVISTA

## Glass Panel Feature

*Excellence and innovation*  
BUILT INTO EVERY DESIGN

### Glass Panels

The SkyVista glass panels have an option for blue or neutral solar control, self-cleaning glass, up to lengths of 3 metres. With a 60% solar heat reflection, that still allows 45% of natural light into the building, it's the best of glazing solutions.

SELF  
CLEANING  
GLASS

OUTSTANDING  
SOLAR  
CONTROL

SUPERB  
THERMAL  
PERFORMANCES

## The Stylish Way of Adding More Light Into Your Home

The SkyVista glass panel feature allows a stylish look internally when plastered and painted. This allows more light into your home without over-heating in the summer.



**SkyVista**  
By SupaLite

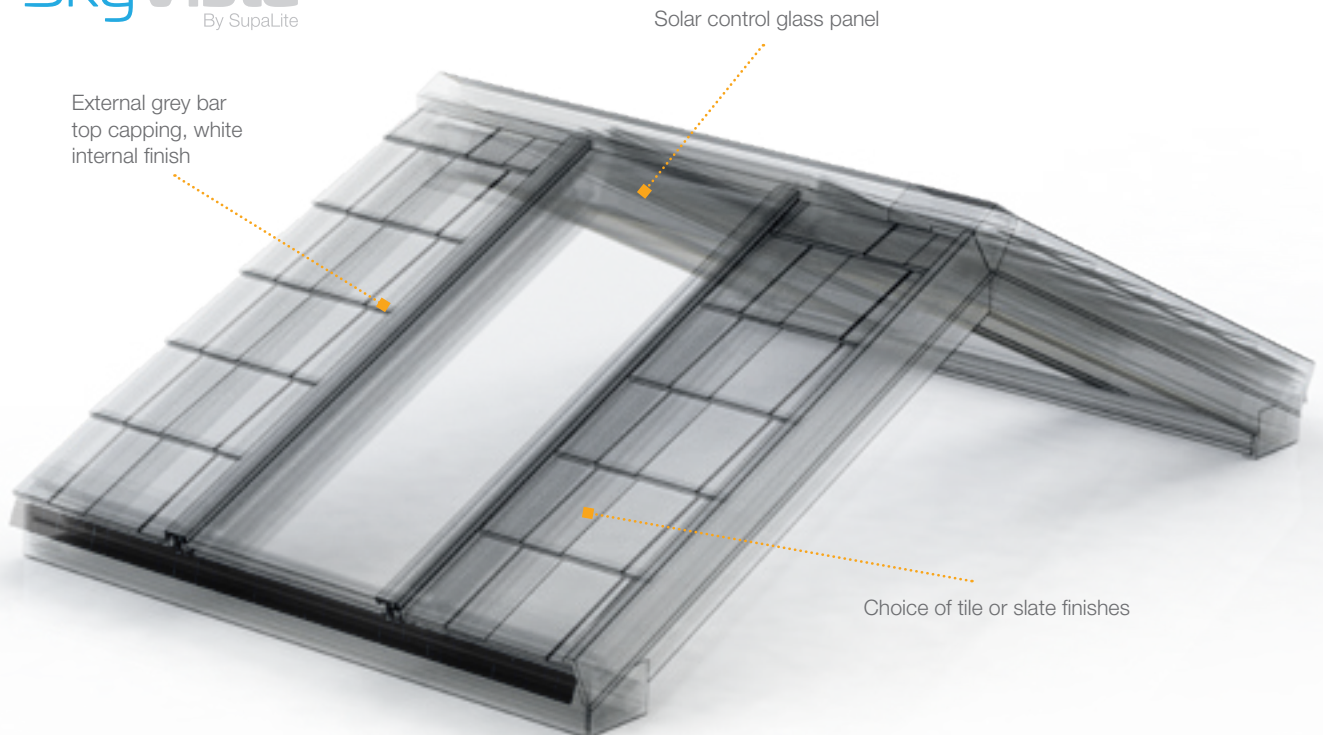

Transforming conservatories into year round living spaces

**SupaLite**  
TILED ROOF SYSTEM

# SupaLite PLUS+

See unique roof feature shown  
in the below roof section

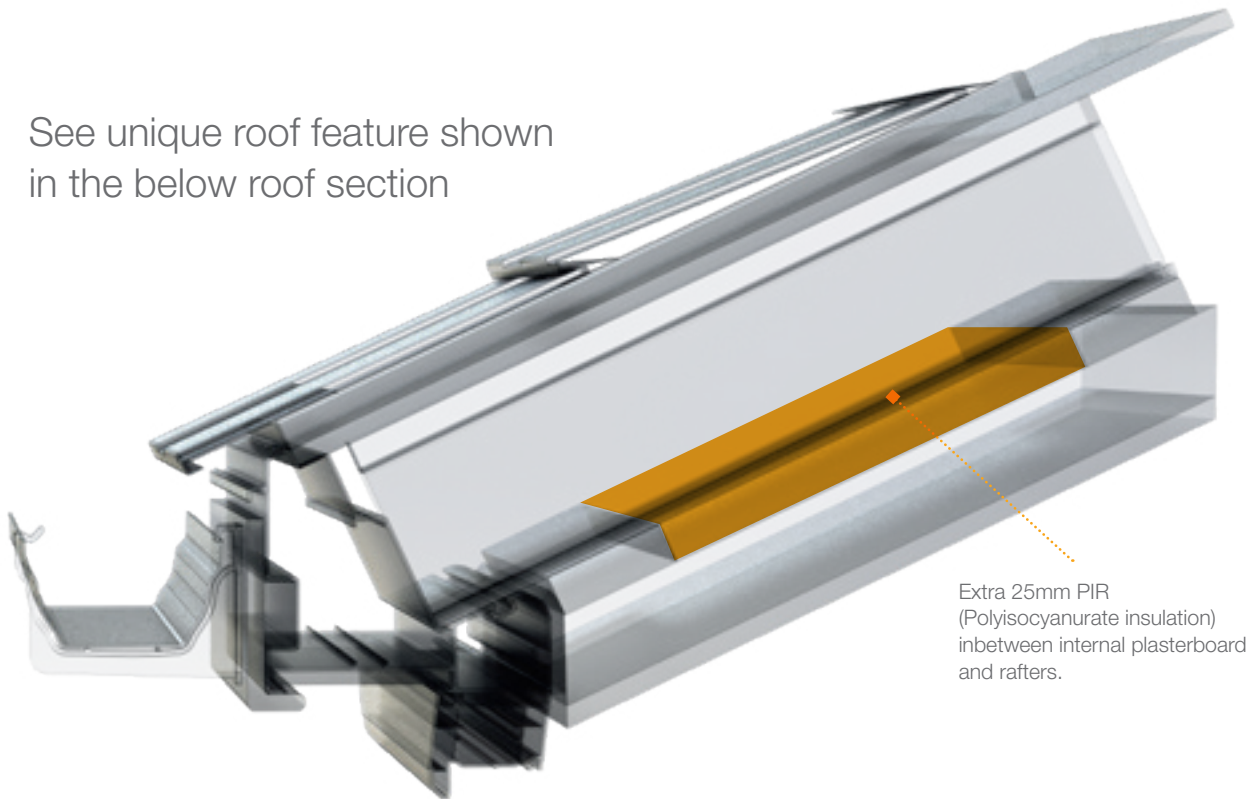

Extra 25mm PIR  
(Polyisocyanurate insulation)  
inbetween internal plasterboard  
and rafters.



**SupaLite**  
PLUS+

The SupaLite PLUS+ specification of roof has been specifically designed and tested to achieve a U-Value of 0.15 W/m<sup>2</sup>.K.

The structure of the SupaLite PLUS+ roof is the same highly acclaimed and popular design as our standard roof, allowing you to enjoy all of the SupaLite benefits. The additional rating has been achieved by the use of extra insulated panels.

For Scotland the roof will require extra ventilation to comply with regulations.



# SupaLite ECO A Compact Design with Minimal Soffit Detail

Restrictions Apply



**SupaLite**  
ECO ROOF

A compact design with minimal soffit detail.

Our SupaLite ECO Roof has been specifically developed to fill a void in the market for a cost effective solution to a solid conservatory roof conversion where minimal overhang is key.

In some situations, the conservatory is positioned tight up to a neighbouring property or boundary that limits the amount of overhang available. Our standard SupaLite Roof is designed to incorporate a soffit detail, just like a conventional roof or extension. This may in some circumstances project over a boundary.

Our ECO Roof design does away with the soffit detail and follows the contours that are similar to what you would find on a polycarbonate conservatory roof.

Transforming conservatories into year round living spaces

**SupaLite**  
TILED ROOF SYSTEM

# ROOF COVERINGS



Charcoal

Ember

Walnut

ExtraLight high performance textured steel tiles are available in 3 colours. With its exceptional durability, the ExtraLight stone-coated steel tile offers superior performance.

## extraLIGHT

LIGHTWEIGHT ROOF TILE SYSTEM

- ✓ **UNIQUE** - A new and unique high performance textured roof tile. The shingle textured-finish tile captures the subtle look and charm of low-profile traditional shingles.
- ✓ **PERFORMANCE** - ExtraLight eliminates the delaminating, lifting and general break-down caused by UV rays and high winds. Enjoy the superior performance of stone-coated steel.
- ✓ **CHOICE** - The ExtraLight Shingle comes in a choice of natural weathered tones to recreate the visual appeal of a clay tiled roof, carefully selected to match most traditional roofs.
- ✓ **APPROVED** - Our tiles are fully registered and compliant with the strict UK & European standards required for use with a roof pitch as low as 10 degrees.

## The Traditional Slate Look

Roofing slate has for centuries been desired for its durability and aesthetic appeal, but it does have drawbacks with its weight, pitch restrictions and brittleness. The SupaLite Composite Slate Roof offers the look of traditional slate while remaining lightweight and hardwearing, boasting a 10-year guarantee. Manufactured by using recyclable materials virgin limestone and polypropylene, its performance has been approved and tested to BBA, BRE and CE standards down to a minimum pitch of 14 degrees.

With a wide choice of 5 colours, this lightweight slate is a common roof covering choice for the SupaLite roof system.



# ACCESSORIES



**EXTERNAL LIGHTING** - The unique design of the SupaLite Roof incorporates an external fascia and deep soffit. Many customers choose external LEDs to be fitted into the soffit creating a feature that is both functional and aesthetically pleasing in the evenings. With long life and low running costs the external LEDs can be left on all night in areas where security is needed.

*Engineering*  
SIMPLICITY & PERFORMANCE

Transforming conservatories into  
all year round living spaces



**HAUNCHES & TIE BARS** - All roofs have to cater for 'Dead Load' (i.e. the weight of the roof).

When the deflections exceed an acceptable level, it is necessary to brace the structure with an additional member, namely a tie bar or haunch.



**COLOURED FASCIAS & SOFFITS** - The soffit board is tucked away under the fascia board. It is usually the fascia and soffit that you see most of from street level. The SupaLite roof system incorporates these to match the existing property aesthetics, including most colour options. It also accommodates external soffit lights.

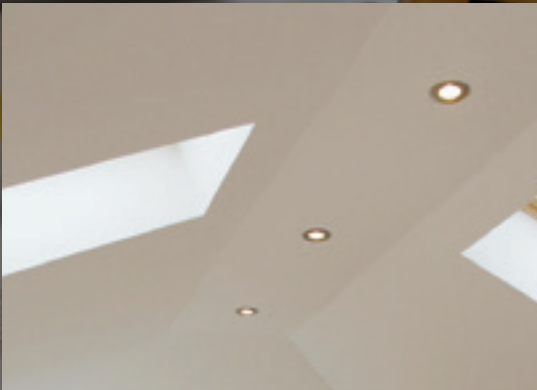

**INTERNAL LIGHTING** - LED ceiling lights are a sleek and stylish way to add energy efficient and up to date lighting to your home. LED bulbs have an impressive life span and use up to 90% less energy. These can be fitted in the ridge bulkhead or a pelmet closer to the eaves beam.



**ROOF WINDOW** - Roof lights and roof ventilation have been in popular use for the past 150 years.

Our high-quality materials, state of the art production techniques and excellent quality control ensure we provide durable, safe and functional roof windows. The internal colour options of our roof windows are white or pine.

# SupaLite ORANGERIES

*Modern*  
LIVING SPACE

**STRUCTURAL** lightweight roof system, engineered and designed to last a lifetime

**INCREDIBLE** U-Value with increased thermal performance, to help save money on your energy bills

**CHOICE** of glazed area with SkyElevate and SkyEdge options

**ADD VALUE** to your home by the feel of an extension for all year round living space

# Transform Your Orangery

A thermally efficient flat roof orangery combining simplicity, performance and flexibility.

The SupaLite Flat Roof Orangery system is the most modern and efficient way to enjoy both the indoors and outdoors whilst remaining light and warm. Perfect for retro-fit or new build purposes, the orangery system comes with all the outstanding features to make it one of the most thermally efficient available in the UK.



It's designed and engineered so it is remarkably quick to install as all roofs are pre-fabricated in a state of the art production facility. Also, the clever design features allow either a lantern style glazing structure or a flat glass glazing structure (SkyEdge – page 25).

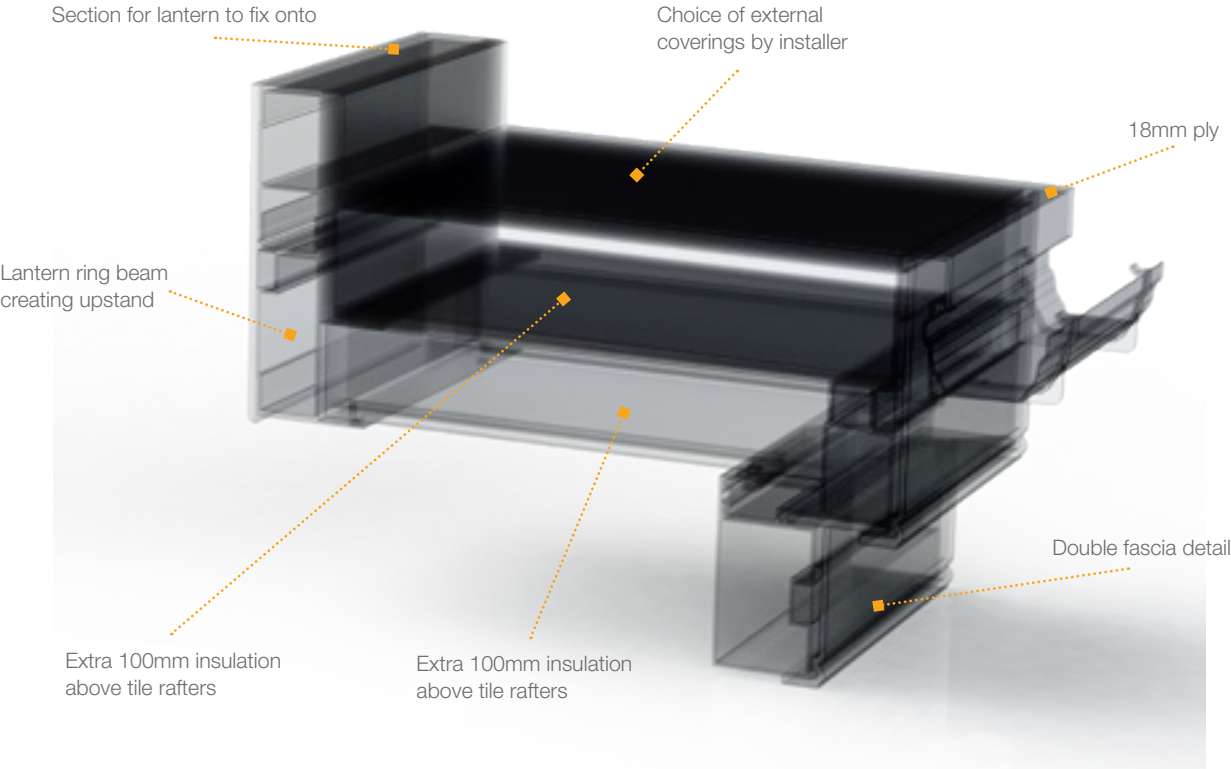

# SupaLite ORANGERIES

*Quality you deserve.*

PERFORMANCE YOU  
CAN COUNT ON

**UNIQUE** optional double fascia detail with choice of colours including guttering

**COLOUR** choice of fascias and guttering to either match or contrast your existing property

**10 YEAR GUARANTEE** The SupaLite Orangery systems are a tried and tested roof, with the system holding accreditations such as BBA, BRE and CORGI

**APPROVED** with Building Regulations certification (charges apply) for replacement conservatory roofs





## SkyElevate

By SupaLite

Beautifully designed, SkyElevate features slim sightlines and a sleek transition of roof bars allowing in more light for an unobstructed view.

With 36 different colour combinations and a choice of solar control, self-cleaning glass, the SkyElevate offers fantastic thermal efficiency as well as being strong and robust.

SkyElevate compliments the SupaLite Orangery systems. Designed and manufactured in Britain, SkyElevate is covered by a 10 year guarantee.



*We have completely remodelled our old conservatory by adding brick columns, bi-folding doors and a SupaLite Orangery to create a modern dining room with an open air feel. It's great for entertaining and the combination of warmth and natural light suits us perfectly. The roof was installed in just one day too!*

**Mr & Mrs Stanworth**

## SkyEdge

By SupaLite

Bringing natural light into your home all year round, the high performance SkyEdge has been designed for a fixed, flat glass solution, which creates a contemporary look for any property.

The SkyEdge is available in a range of sizes and a choice of glazing solutions to compliment the anthracite grey lightweight aluminium frame. This product also features unique concealed fixings ensuring an elegant and unobtrusive look.

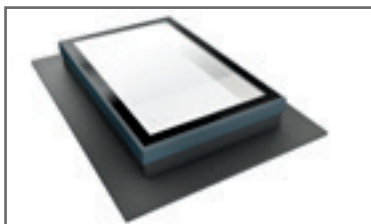

# Superior Glazed **ALUMINUM VERANDAS**

*Maximise*

YOUR INDOOR TO  
OUTDOOR SPACE

The SupaLite Veranda has been carefully designed to be flexible to suit almost any arrangement or permutation. The Veranda columns can be supplied in any RAL colour.

## Combining both Traditional and Contemporary Features

The SupaLite Veranda system is a bespoke solution to maximise your valuable indoor to outdoor space and can be an elegant addition to your property. Each veranda is individually designed to perfectly suit your property and attached with ease to the side or rear of your home, allowing you to enjoy outdoor living and entertaining space.

It is also compatible with the SupaLite Tiled Roof Systems or even as a stand-alone structure.



*Our freestanding veranda over our hot tub allows us to enjoy and relax whatever the weather. It was installed in just one day. We're delighted with it.*

Mrs Richardson

### Features

Adjustable angles from 5° through to 35° and cores strength allowing for projections up to 4000mm

- ✓ Choice of Column Styling
- ✓ Modular Design with Universal Fittings
- ✓ Lean-to or Stand Alone Variations
- ✓ Choice of Glazing Options

# Building Regulations

Applicable in England and Wales  
(excludes Northern Ireland, Channel Islands and Scotland)

- To take the stress and uncertainty out of the situation, SupaLite can facilitate the complete Building Control Certification process on your installation company's behalf. (Replacement roof only).
- Conservatory roof conversions without a Building Regulations certificate can cause additional cost and major delays when selling a property.
- A building control certificate can provide peace of mind that the installation conforms to all current regulations. We hope that this provides you, the homeowner with the confidence that you are buying through a reputable company.
- Building Regulations certificates are ONLY EVER issued by companies that offer a complete roof replacement.

**100%**

### EASY APPLICATION

Obtaining a building certificate for your solid conservatory roof could not be easier

**100%**

### HEADACHE FREE

We facilitate the whole process and take away the headache and stress

**100%**

### IN-HOUSE EXPERTS

All applications are handled by our qualified in-house experts who are happy to answer your queries

**100%**

### PEACE OF MIND

Be assured your investment is protected by working with a respected company

**100%**

### NATIONAL COVER

Nationwide coverage throughout England & Wales

**100%**

### AMAZING VALUE

We work hard on your behalf to keep costs low. We aim to be the best value on the market

## Questions to ask?

- Building regulation certificate issued (if applied for)
- Compliant to JHAI specification
- SupaLite 10 year guarantee
- Structurally proven even under heavy snowfall
- Roof structure designed to take plasterboard, tiles & vents
- Thermally efficient cool in summer, warm in winter
- Free from mould and condensation
- Free from solicitor issues if the house is sold
- A worry free all year round living space for the homeowner

**SupaLite**  
TILED ROOF SYSTEM

Non-Compliant  
Roofs

✓	✗
✓	✗
✓	✗
✓	✗
✓	✗
✓	✗
✓	✗
✓	✗
✓	✗

**CLIENT  
PEACE OF  
MIND**

## Did you know?

If the council are made aware of a clad-over roof being installed at a property, they will enforce you to remove it.



# BEWARE of Clad-overs!

## WHAT IS A CLAD-OVER?

Some companies simply clad-over the existing conservatory roof internally, externally or both. Either way, they plan to use the existing structure that was only ever designed for its original purpose. These will be more competitively priced but may not meet Building Regulation Approval. Don't be frightened of asking the builder/installer about the following:

### U-VALUE

Does the new structure achieve the correct U-Value for insulation properties?

### CONDENSATION

Are there thermal barriers and enough air ventilation in place? Ask to see a small product sample if needed for proof of this.

### STRUCTURAL INTEGRITY / CALCULATIONS

Can the new roof structure withstand wind and snow loadings? If in doubt request structural calculations for the roof. If this is a tried and tested system, these will be available.

### WEIGHT

Clad-over companies simply remove your polycarbonate or glass and clad-over a structure designed to carry a lot less weight, tiled roofs need to be stronger to prevent plaster cracking.

### WARRANTY

What guarantee will you get and will your home insurance pay-out if there's a problem?

Make the right decision by choosing a SupaLite roof and not a 'clad-over' when replacing your existing conservatory roof.

Having peace of mind and knowing that you can get payback on your investment is vital and installing a SupaLite roof will give you just that. Combining this with Building Regulations approval means that, if you come to sell your property the structure will be a fully compliant living space.

“ We got three separate quotations when considering replacing our conservatory roof. One of them was several £1000s cheaper which we considered initially. It was only when I asked for some evidence of the proposed roof performance structurally and insulation figures we quickly changed our mind! I'm so glad we did as our new SupaLite roof came with Building Regulations and we know that we'll get back the money we spent on the work, if we come to sell our house. ”

Mr & Mrs Hewit

**What is the weight, per square meter, for a SupaLite tiled roof?**

The weight of the tiled roof is 46kg per m<sup>2</sup>, however, this may vary by roof style.

**Do I get a guarantee with the SupaLite roof? If so, how long does this last and what is covered in the guarantee?**

We provide a 10-year product guarantee on our SupaLite roofs. This is from SupaLite to the installer who will then pass this on to you.

**Typically, how long does it take to install the SupaLite conservatory roof?**

Typically, it would take 3 - 4 days to install a SupaLite conservatory roof for a standard sized 4m x 4m Edwardian style conservatory.

**Do I need to get planning permission to install a SupaLite conservatory roof?**

Planning permission is generally not required to install a SupaLite conservatory roof, if you are only replacing the roof on your existing conservatory. However, if your existing conservatory needed permission you may need permission to change the roof.

**Will having a SupaLite conservatory roof increase the value of my home? If so, by how much?**

A SupaLite conservatory roof will certainly increase the value of your home if it is fitted and supplied with a Building Regulations certificate. Please ensure your installation company offer this with your roof.

**Will it make the room darker if I have a SupaLite conservatory roof installed?**

There is a possibility that your room may be darker once you replace your existing roof with a SupaLite conservatory roof, there are ways of making your new room lighter. This includes painting the ceiling in white, internal spot lights, Roof Windows and SkyVista glass panels.

**Are building regulation plans included when I purchase a SupaLite conservatory roof?**

No, although we can process Building Regulations application on behalf of your installer.

## Installers Nationwide

Find out more about replacing your glass conservatory roof with a SupaLite Tiled Roof System by visiting our website [www.supaliteroof.co.uk](http://www.supaliteroof.co.uk).

Insist on the best,  
insist on **SupaLite**



# SupaLite Accreditations



### BBA Certification

The ExtraLight tile is BBA certified via the manufacturers application in November 2017.



### CORGI Certification

SupaLite are the first tiled roof company to be assessed and issued with membership of the respected CORGI Fenestration scheme for supply chain quality and continuity.



### BRE Certification

The SupaLite roof was tested using Wufi software to ensure the roof is free from risk of condensation. BRE have also carried out water/weather testing with a pass to EN15026.



### JHAI Systems Approval

SupaLite are partnered with JHAI for building control to ensure installations are compliant with regulations. Homeowner certificates\* are issued from JHAI along with SupaLite guarantees.

ENGINEERING SIMPLICITY & PERFORMANCE



*Join the revolution*  
INSIST ON A SUPALITE ROOF



[www.supaliteroof.co.uk](http://www.supaliteroof.co.uk)